

Maßblatt: K2

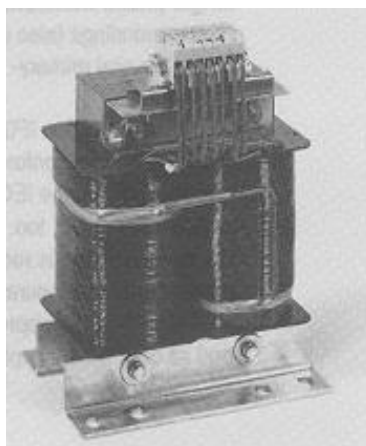

**+ BÜRKLE
SCHÖCK**

Einphasen-Transformator UI-Schnitt stehend

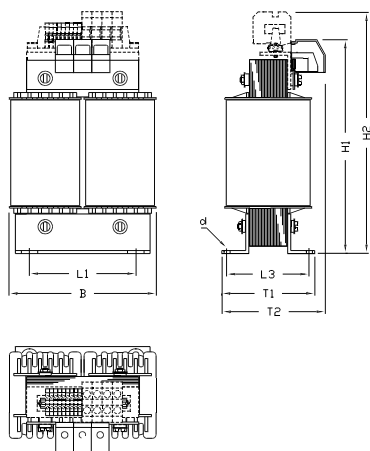

Einphasen-Transformator mit getrennten Wicklungen (auch Spartransformatoren), mit einer oder mit mehreren Primär- und Sekundärspannungen
Schutzart IP00.

Die Transformatoren entsprechen den VDE- Vorschriften, der IEC-Norm CE-konform

Die Nennleistung verringert sich beim Einbau in ein Gehäuse:

ab IP23 - IP32 um ca. 5-20%
ab IP44 um ca. 30-50%

Maßtabelle:

Baugröße Bürklee+Schöck	B	T2	H1	H2	L1	L3	d	Gewicht ca. in kg	Blech- gehäuse
U* 2021	82	62	130	164	60	46	5,0	1,6	WIII
U* 2031	82	72	130	164	60	56	5,0	2,0	WIII
U* 2526	102	78	140	190	80	58	8,0	2,7	WIII
U* 2541	102	93	140	190	80	73	8,0	3,5	WIII
U* 3030	120	81	160	220	100	57	8,0	4,7	WIII
U* 3041	120	93	160	220	100	69	8,0	5,6	WIII
U* 3051	120	103	160	220	100	79	8,0	7,0	WIII
U* 3537	140	99	180	240	103	79	8,0	8,9	H26
U* 3545	140	106	180	240	103	86	8,0	10,2	H26
U* 3555	140	116	180	240	103	96	8,0	12,1	H26
U* 3840	154	125	206	266	104	99	8,0	9,0	H26
U* 3864	154	149	206	266	104	123	8,0	14,0	H26
U* 4041	160	122	207	268	110	96	11,0	9,0	H26
U* 4051	160	132	207	268	110	106	11,0	11,5	H26
U* 4061	160	142	207	268	110	116	11,0	14,0	H26
U* 4070	160	151	207	268	110	125	11,0	16,0	H26
U* 4075	160	156	207	268	110	129	11,0	18,5	H26
U* 4446	180	127	230	286	128	101	11,0	16,0	H26
U* 4460	180	141	230	286	128	115	11,0	18,0	H26
U* 4472	180	163	230	286	128	126	11,0	20,0	H26
U* 5036	205	147	260	326	140	105	11,0	14,0	H28
U* 5044	205	155	260	326	140	113	11,0	16,0	H28
U* 5052	205	163	260	326	140	121	11,0	17,5	H28
U* 5065	205	176	260	326	140	134	11,0	19,8	H28
U* 5077	205	188	260	326	140	146	11,0	22,0	H28
U* 5092	205	203	260	326	140	161	11,0	27,5	H28
U* 50103	205	214	260	326	140	172	11,0	32,5	H28

Maße sind ca Maße in mm
Änderungen vorbehalten

circa dimensions (mm)
subject to alterations

dimensions approximates eb mm
soU* réserve de modifications

U = UI-Schnitt

*= 2. Buchstabe, der die Blechqualität und somit die Kernleistung festlegt.

D-70565 STUTTGART BÜRKLE + SCHÖCK GEWERBESTRAßE 38

TELEFON 0711/7837-100



TELEFAX 0711/7837-129

Maßblatt: K2



**BÜRKLE
+ SCHÖCK**

Einphasen-Transformator UI-Schnitt stehend

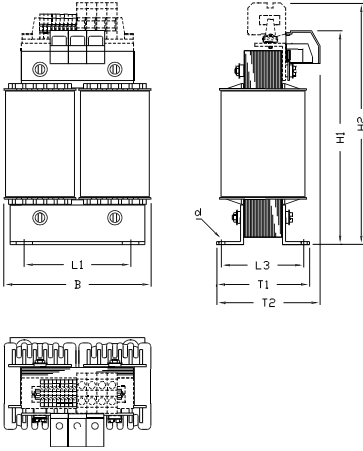

Single-phase transformers with separate windings (also autotransformers).
 One or several primary- and secondary voltages.
 Degree of protection IP00.
 The transformers conform to the VDE regulations, the IEC standard and conform to CE, too.
 The nominal rating is reduced, when installed in an enclosure as of
 IP23 - IP32 by approx. 5-20%
 and as of IP44 by approx. 30-50%

Transformateur monophasé avec bobinages séparés (autotransformateur également). Une ou plusieurs tensions primaire et secondaire.
 Classe de protection IP00.
 Les transformateurs sont conformes aux prescriptions VDE, aux normes IEC et aux CE.
 La puissance nominale se réduit si montage d'un boîtier à partir de
 IP23 - IP32 de 5-20% env.
 de IP44 de 30-50% env.

Maßtabelle:

Baugröße Bürkle+Schöck	B	T2	H1	H2	L1	L3	d	Gewicht ca. in kg	Blechgehäuse
U* 5658	230	159	290	350	190	117	11,0	29,0	H30
U* 5692	230	193	290	350	190	151	11,0	42,5	H30
U* 6045	240	146	310	410	200	107	11,0	23,0	H30
U* 6054	240	154	310	410	200	116	11,0	27,0	H30
U* 6063	240	164	310	410	200	125	11,0	32,0	H30
U* 6078	240	179	310	410	200	141	11,0	41,0	H30
U* 6093	240	194	310	410	200	156	11,0	46,0	H30
U* 7044	280	210	360	460	240	123	11,0	41,0	H30
U* 7053	280	220	360	460	240	132	11,0	44,0	H30
U* 7063	280	230	360	460	240	142	11,0	48,0	H30
U* 7073	280	230	360	460	240	152	11,0	52,0	H30
U* 7088	280	235	360	460	240	167	11,0	57,5	H30
U* 70103	280	235	360	460	240	182	11,0	63,0	H30
U* 70133	280	254	360	460	240	211	11,0	88,0	H30
U* 8061	320	245	410	510	270	162	13,0	75,0	H30 / H150
U* 8072	320	245	410	510	270	173	13,0	80,0	H30 / H150
U* 8083	320	255	410	510	270	184	13,0	90,0	H30 / H150
U* 8095	320	260	410	510	270	196	13,0	101,0	H30 / H150
U* 80110	320	270	410	510	270	211	13,0	135,0	H30 / H150
U* 80125	320	280	410	510	270	226	13,0	146,0	H30 / H150
U* 80140	320	300	410	510	270	241	13,0	155,0	H30 / H150

Maße sind ca. Maße in mm
Änderungen vorbehalten

circa dimensions (mm)
subject to alterations

dimensions approximatives eb mm
soU* réserve de modifications

U = UI-Schnitt

* = 2. Buchstabe, der die Blechqualität und somit die Kernleistung festlegt.

D-70565 STUTTGART BÜRKLE + SCHÖCK GEWERBESTRAßE 38

TELEFON 0711/7837-100



TELEFAX 0711/7837-129